



RESIDENTIAL
CONTROL
VALVES

Electronic Control Valve

BR-X Series

The Pentair BR-X Series Electronic Control Valve offers an economical solution for residential water conditioning applications. The valve features the patented Fleck® piston seal spacer technology and solid state microprocessing. BR-X is an upgrade to the BR-C series, It is an outstanding combination of value and performance.

Three models available for softening and filter applications.

Typical Applications

- Water Softener
- Filter (Iron Sediment, Carbon, Neutralizing)



Smart, Sustainable Water Solutions.

FOR LIFE.

Electronic Control Valve

BR-X Series

Features and Benefits

- **4-Way Regeneration –**
Meter delayed, meter immediate, time clock and day of week.
- **Easy Operation – SXT LCD**
screen clearly displays easy-to-understand operating modes: time of day, remaining capacity, regeneration cycle in process. Programmable for backwash or regeneration setting.
- **Proven Performance –**
Incorporates Fleck piston seal spacer technology for reliable and efficient operation.
- **Rugged Materials –**
ABS and fiberglass components resist corrosion and contaminant build-up.



Three Models Available
 BR-XFT – Electronic Filter Valve
 BR-XST – Electronic Softener Valve
 BR-XSM – Electronic Softener Valve with Meter

Operating Specifications

Valve Specifications			
Valve Material	ABS and fiberglass	Drain Line	1/2" NPTF
Inlet/Outlet	1", 3/4" (BSP or NPT)	Brine Line (for softener)	3/8" Fitting
Cycles	3 (filter), 5 (softener)	Electrical Rating	24V, 50/60Hz
Working Pressure	20-80 psi (1.4-5.5 bar)	Transformer (included)	220V-24V/120V-24V AC
Temperature	34-104°F (1-40°C)	Regeneration	Downflow
Mounting Base	2-1/2" – 8 NPSM	Estimated Weight	7 lbs (3 kg)
Distributor Pilot	1.05" pipe O.D.		
Flow Rates			
Continuous (10 psi drop)	20 gpm	Max. Backwash (25 psi drop)	7 gpm
Meter Information (if applicable)			
Meter accuracy range	+/- 5%	Meter Capacity Range (m ³)	2.3-40 m ³ maximum

Dimensions (unit: mm)

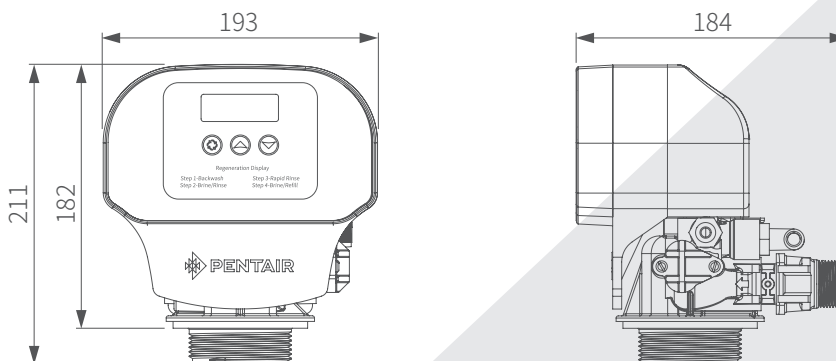

Pentair Water (Factory)

Add.: No. 371, Heshan Road, New District, Suzhou China. 215011

Tel.: 86 512 66617690 Fax.: 86 512 66611178

Website: www.pentairwater.cn Hot line: 800-820-6671

©2010 Pentair Residential Filtration, LLC
 43102 Rev A SE10